

NU1508: High Performance Wireless Power Transmitter Controller

Feature

- Input Voltage: 4.5V to 5.5V
- Integrated ARM® Cortex®-M0
- Compliant with WPC 1.2.4 to Work with A11 and A11a Coils
- Reliable and Accurate Foreign Object Detection (FOD)
- LED for Charging Status and Fault Reporting
- PWM Output from 110KHz to 205KHz
- Input Low Voltage Detection
- Limited Power to Prevent Overloading Input Sources
- Over-Current Protection
- Over-Temperature Protection with NTC Input
- Buzzer Output for Charging Status
- Internal Oscillator
- Interface with NU1008 to Form High Performance 5W Transmitter Solution
- 28 Pin 4mm x4mm QFN Package

Applications

- Wireless Power Transmitter Compliant with WPC V1.2.4 BPP
- Embedded Wireless Power Transmitter for Smart Home
- General Wireless Power Transmitter for Consumer, Industrial and Medical Applications

Descriptions

NU1508 is a highly integrated digital controller for wireless power transmitter compliant with WPC 1.2.4 BPP standard. This device and NU1008, the companion power stage IC, form simple, high-performance and cost-effective wireless power transmitter solutions suitable for a wide range of applications.

NU1508 integrates all essential functions to deliver regulated power and maintain robust communications with WPC compliant receivers. Used with NU1008, the smallest and most integrated power stage IC, the two-chip turnkey design provides the most space saving solutions.

NU1508 also emphasizes on providing reliable and robust charging experience by preventing any transient conditions, such as receiver load variations and Rx/Tx coupling changes, from disrupting communications and continuous charging. The device adopts a proven foreign object detection (FOD) scheme to detect metal objects and prevent harmful heating. The device also integrates the protection features such as over-temperature and over-current protections, input low-voltage detection and input power limit

Block Diagram

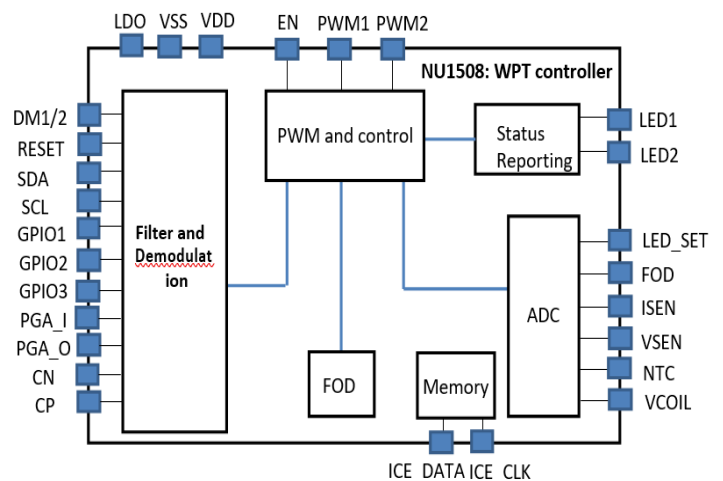

IMPORTANT NOTICE AND DISCLAIMER

Any information in this document is prohibited from being used, reproduced or disseminated, modified, translated to any third party in any form and/or through any means without the prior written consent of NuVolta. ALL RIGHTS RESERVED

Disclaimer

Information in this document is for your reference only and is subject to change without notice. It is your responsibility to ensure its application complies with technical specifications.

NuVolta Technologies Inc (hereafter referred to as “NuVolta”) makes no representation or guarantee for this information, express or implied, oral or written, statutory or otherwise, including but not limited to representation or guarantee for its application, quality, performance, merchantability or fitness for a particular purpose. NuVolta shall assume no responsibility for this information and relevant consequences arising out of the use of such information.

Under the protection of NuVolta intellectual property rights, no license may be transferred implicitly or by any other means.

Trademarks

NuVolta and NuVolta logo are trademarks of NuVolta Technologies Inc. All trademarks and registered trademarks are the property of their respective owners.